

APPLICATION NOTE 22

PSRR (Power Supply Rejection Ratio) testing

This application note describes test techniques for the analysis of “PSRR – Power Supply Rejection Ratio”. In the production of this application note, the LM317 HVT DC regulator was chosen as this chip is a readily available regulator chip with well documented PSRR behaviour.

The instrument selected for this test was the N4L PSM3750, this is a 10uHz to 50MHz Frequency Response Analyzer with isolated inputs and an Isolated Generator both to 500Vpk. An N4L PPA1530 Power Analyzer was used in order to monitor the output power of the regulator to ensure the regulator remained stable and within its output power limits. A load of 190ohms was placed on the output of the regulator chip.

What is PSRR?

PSRR is an acronym for “**P**ower **S**upply **R**ejection **R**atio”, it a measurement calculated in dB as follows;

$$PSRR (dB) = 20 \log \left(\frac{V_{in}}{V_{out}} \right)$$

This PSRR value is usually given across a frequency range specified by the chip manufacturer, fig.3 illustrates such a “Frequency response” up to 1MHz.

This dB value is the ratio of V_{in}/V_{out} , with respect to a perturbation signal presented to the input of the regulator chip in this instance (V_{in}) and the resultant amplitude of this same signal at the output (V_{out})

The ratio of these signals (V_{in}/V_{out}) is a reflection of the regulator circuits ability to maintain a constant DC output when presented with a noisy input supply (As is the case in real life circuits and a very important part of the DC regulators specification – to regulate)

How do you test PSRR?

PSRR is tested by injection of a perturbation signal at the input of the test circuit, measurement of this perturbation signal at the input and simultaneous measurement of the same signal at the output. The ratio of the amplitude of these two measurements of the same frequency component of the original injected perturbation signal reflects the ability of the regulator to “suppress” this perturbation, the greater the ability to regulate, the higher the PSRR.

If you are familiar with the techniques employed by frequency response analyzers, you will be confident that you have the ability to selectively measure the perturbation signal (a sine

PSRR (Power Supply Rejection Ratio) Testing	525-022	Issue 1
Newtons4th Ltd 30 Loughborough Rd Mountsorrel Loughborough LE12 7AT UK Tel: +44 (0)116 2301066		

wave) at the input and the output. The difficult part of this measurement is in fact the injection of the perturbation signal upon the input.

For this we have two options from the N4L range;

1. An N4L LPA Power amplifier + PSM17xx/37xx Frequency Response Analyzer
2. A PSM3750 (Featuring an Isolated generator) + “Injection Inductor” + Generic low cost DC supply

Option 1 has historically been the natural option; this offers many benefits however it does have the limitation that the addition of the high frequency power amplifier adds some cost and complexity to the test setup. With the introduction of the PSM3750 frequency response analyzer and its isolated generator we now have a second option to offer the engineer.

The isolated generator is very beneficial in this application; we will insert a low series resistance 1mH inductor in series with the standard low cost DC supply at V_{IN} . The inductor chosen in this case was 0.3 Ohms resistive, lower series resistance inductors are available. This will provide a low voltage drop between the DC source and DC regulator at DC and higher impedance to the injected perturbation signal at higher frequencies.

The basic circuit used for this test is illustrated below;

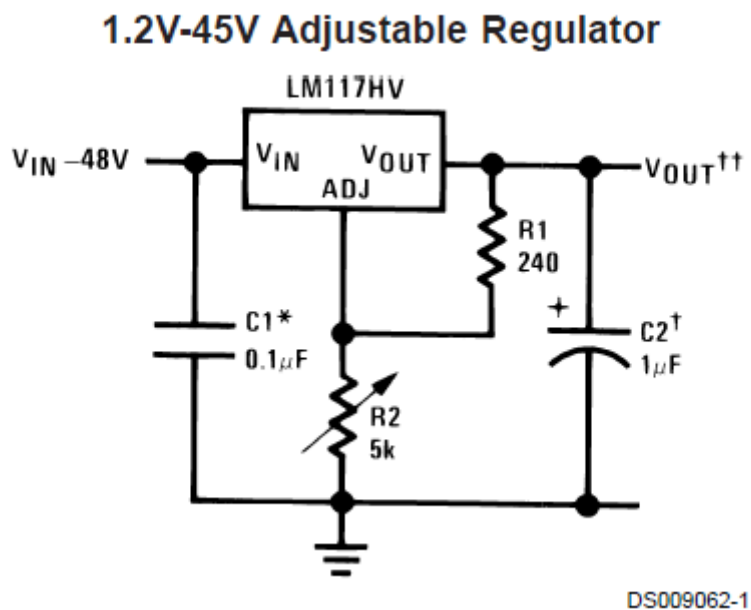

Fig.1

The capacitors on the input and output were not fitted for this test.

PSRR (Power Supply Rejection Ratio) Testing	525-022	Issue 1
Newtons4th Ltd 30 Loughborough Rd Mountsorrel Loughborough LE12 7AT UK Tel: +44 (0)116 2301066		

Test Setup

A DC power supply was configured with a level of 8V, the output voltage of the regulator was set to 2V initially with a 19.49Ω load on the output consuming 202.14mW as shown on the PPA1530 Power analyzer screenshot below.

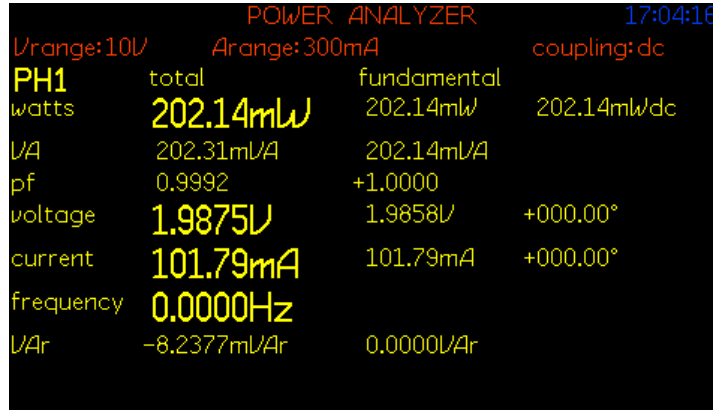

Fig.2

The ripple rejection ratio is stated as follows in the LM317 datasheet, 65dB typical at 120Hz.

		Min	Typ		
Ripple Rejection Ratio	$V_{OUT} = 10V, f = 120\text{ Hz}$	66	65		dB
	$C_{ADJ} = 10\ \mu F$	66	80		dB

Fig.3

The ripple rejection with respect to frequency up to 1MHz is as follows;

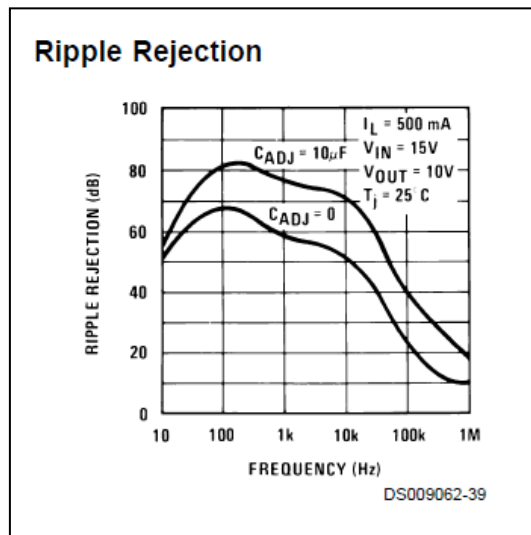

Fig.3

PSRR (Power Supply Rejection Ratio) Testing	525-022	Issue 1
Newtons4th Ltd 30 Loughborough Rd Mountsorrel Loughborough LE12 7AT UK Tel: +44 (0)116 2301066		

The final test circuit is illustrated below in Fig.4, notice the PSM3750 generator connected across the injection inductor.

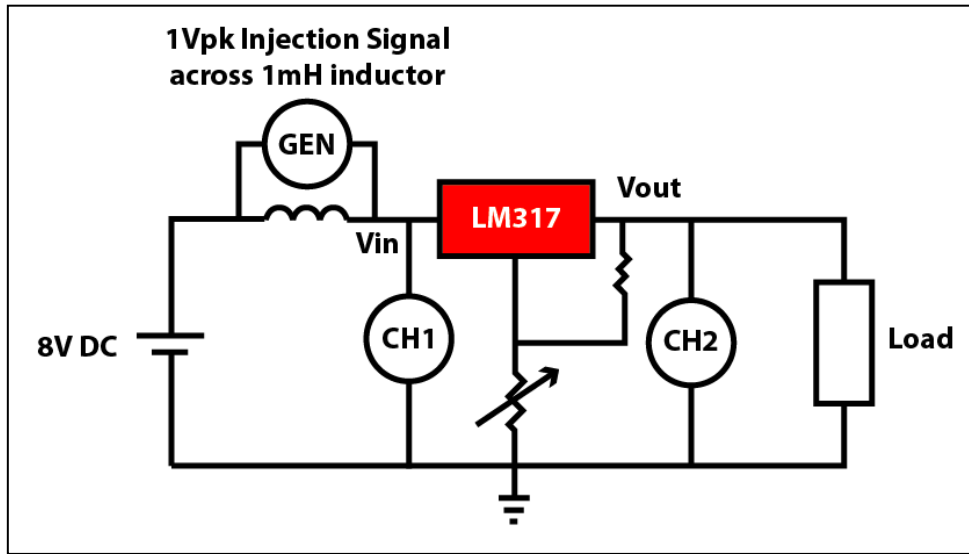

Fig.4

The circuit was built on a prototyping board

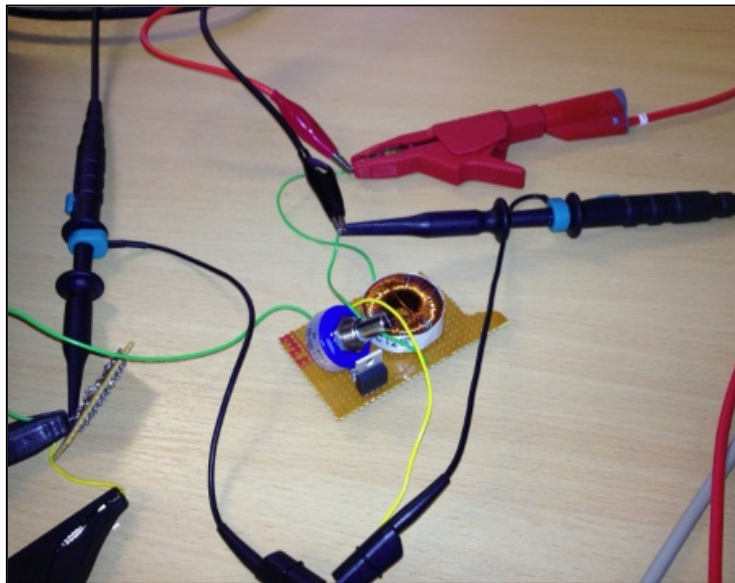

Fig.5

PSRR (Power Supply Rejection Ratio) Testing	525-022	Issue 1
Newtons4th Ltd 30 Loughborough Rd Mountsorrel Loughborough LE12 7AT UK Tel: +44 (0)116 2301066		

The PSM3750 and DC supply were connected

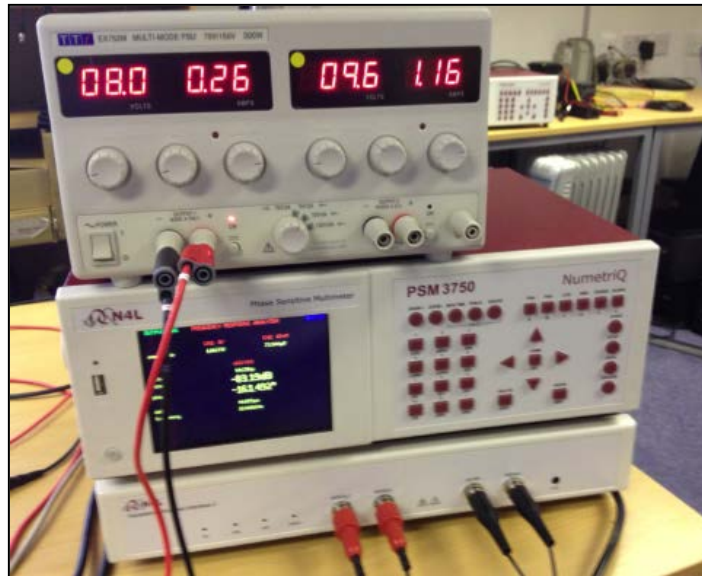

Fig.6

The PPA1530 Power Analyzer was connected to the output



Fig.7

Circuit behaviour

Some pertinent points to remember are that the Generator has 50Ω output impedance, this results in a lower injection voltage across the inductor at lower frequencies as the impedance ($2\pi fL$) of the inductor is low, this injected voltage will rise with frequency as the 1mH inductor exhibits higher impedance at higher frequencies. As the generator is isolated there is no requirement for an injection transformer and the inputs of the PSM3750 are very selective, resulting in reliable results at low frequencies.

PSRR (Power Supply Rejection Ratio) Testing	525-022	Issue 1
Newtons4th Ltd 30 Loughborough Rd Mountsorrel Loughborough LE12 7AT UK Tel: +44 (0)116 2301066		

Measurements with the PSM3750 and recording to PSMComm software

When the generator is first turned on, we set an injection frequency of 10kHz with an amplitude of 1V, see below for a screen shot of the PSM3750 “real time” display.

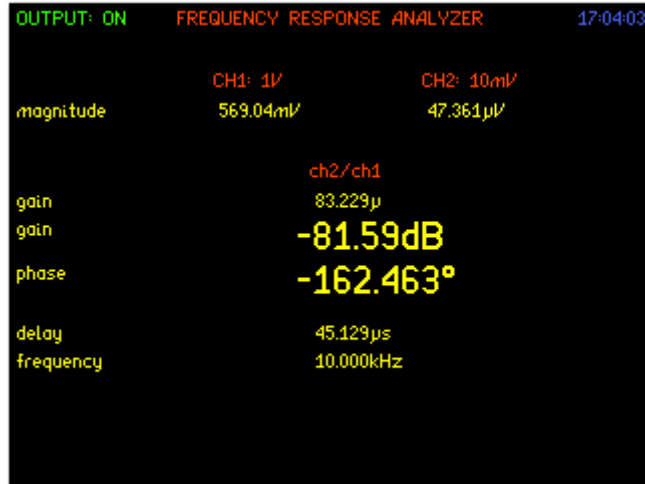

Fig.8

Initially we see good results of -81.59dB (dB = CH2/CH1) attenuation of the injection signal, measuring an input amplitude of 569.04mV (Vin, CH1) with only 47.361uV measured at the output (Vout, CH2) As shown in the screenshot, although the AC injection signal is superimposed on top of the 8V DC supply signal, CH1 has auto ranged to the 1V range and CH2 to the 10mV range due to AC coupling being set on the PSM3750, this enables the input to be sensitive to small AC perturbation signal upon a large DC offset.

Oscilloscope mode on the PSM3750

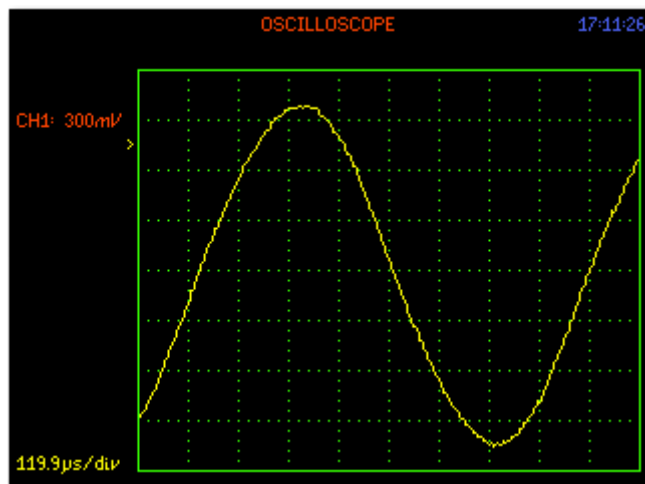

Fig.9

PSRR (Power Supply Rejection Ratio) Testing	525-022	Issue 1
Newtons4th Ltd 30 Loughborough Rd Mountsorrel Loughborough LE12 7AT UK Tel: +44 (0)116 2301066		

As illustrated, the injection signal is clean and relatively undistorted
 2V(Red) output and 4V(Green) output plotted using PSMComm N4L software.

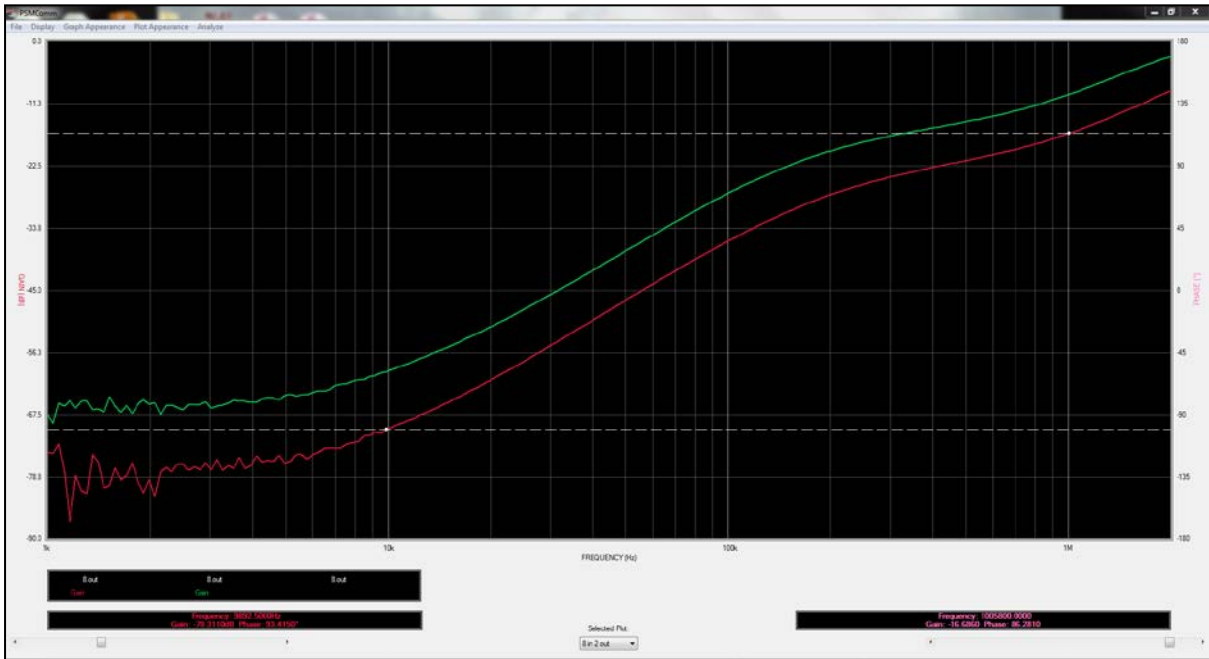

Fig.10

The plots illustrate that the PSRR is significantly affected by the Input/Output voltage differential, with better results being offered by greater differential voltages.

Conclusion

The PSM3750 performs very well when measuring PSRR, use of the floating generator coupled with an injection inductor provides excellent characterisation of the regulator. Utilising the high selectivity of the PSM3750 inputs, signals in the lower uV range are easily measured whilst connected to higher voltage DC lines. PSMComm software offers quick, easy comparison of results.

For more information on the PSM3750 please visit
<http://www.newtons4th.com/products/frequency-response-analyzers>

PSRR (Power Supply Rejection Ratio) Testing	525-022	Issue 1
Newtons4th Ltd 30 Loughborough Rd Mountsorrel Loughborough LE12 7AT UK Tel: +44 (0)116 2301066		